

B

5、 FA Flange type

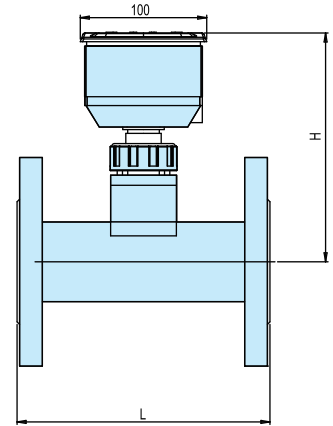
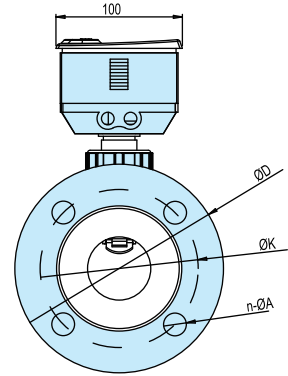

External dimensions

Unit: mm

DN		Pressure MPa	L	D	K	n- $\varnothing A$	H
32	1¼"	≤0.8	200	140	100	4- $\varnothing 18$	187
40	1½"		200	150	110	4- $\varnothing 18$	192
50	2"		200	165	125	4- $\varnothing 18$	198.5
65	2½"		200	185	145	8- $\varnothing 18$	205
80	3"		200	200	160	8- $\varnothing 18$	212
100	4"		250	220	180	8- $\varnothing 18$	222
125	5"		250	250	210	8- $\varnothing 18$	233
150	6"		300	285	240	8- $\varnothing 22$	247
200	8"		350	340	295	8- $\varnothing 22$	267
250	10"		400	395	350	12- $\varnothing 22$	287

6、 KA Tri-clamp type (DIN standard)

External dimensions

Unit: mm

DN		Pressure MPa	L	D	H
32	1¼"	≤0.8	200	50.5	187
40	1½"		200	64	192
50	2"		200	76	198.5
65	2½"		200	99	205
80	3"		200	108	212
100	4"		250	115	222

